



Operating instructions

RC SET

Transmitter T-301

Receiver R-301

Charger C-U01



DIGITAL PROPORTIONAL SYSTEM

2.4GHZ T-301

Transmitter T-301 Operating Instructions

System Specifications

Model: **T-301**

Output Power: <100mW

Operating Voltage: 4.8 or 6V

Power Supply: 4 Cell Alkaline/Ni-Cd/Ni-MH

Frequency/Modulation Type: 2.4GHz FHSS

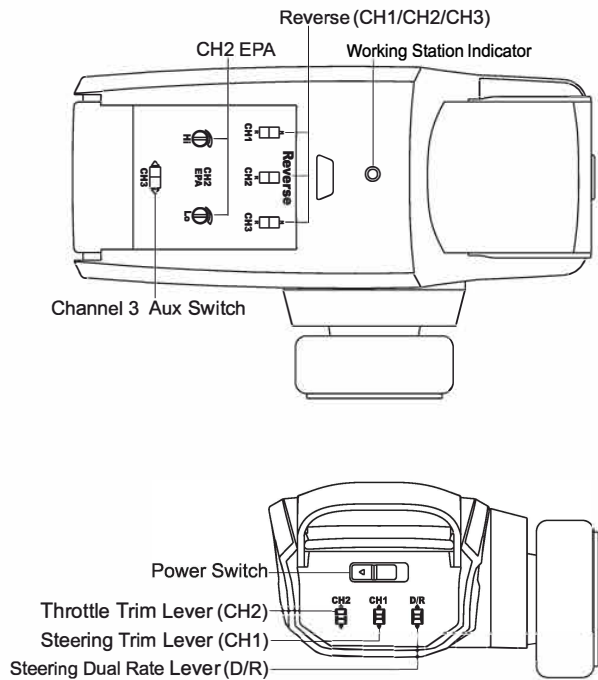
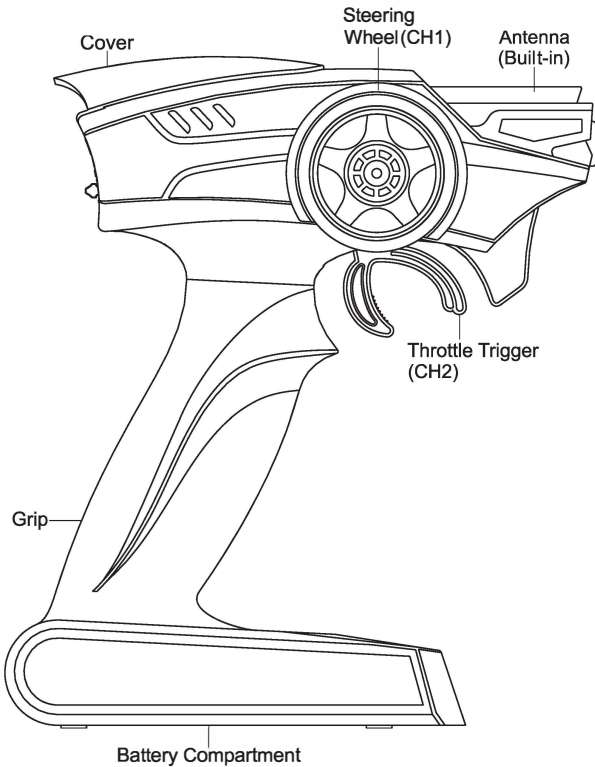

Installing the Transmitter Batteries



Open the battery holding tray. Insert 4 AA batteries into the marked spaces. Please note the correct direction of the batteries.

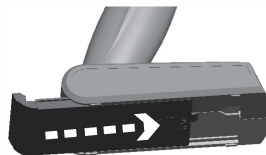

Incorrect battery insertion could damage the transmitter. This 2.4Ghz transmitter has an internal Antenna.

Installing the battery pack



You need to insert the battery pack in the open section for the battery. Use the chassis cut-out for corner wiring if needed. Use the straps provided to secure the battery in place.

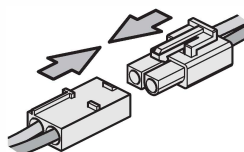

Once fastened and secured please connect the battery plug into the speed controller plug noting correct polarity. Red to red, black to black.

CH1(Steering) Trim

Up
Down
CH1

Left Right
Steering Wheel

If the wheels point left, turn CH1 downward .

If they point straight no adjustment required.

If wheels point right, turn CH1 upward.

CH1(Steering Dual-Rate)D/R

Up
Down
D/R

Left Right
Steering Wheel

If the steering angle is too small, adjust the D/R upward .

If the steering angle is too large, adjust the D/R downward.

CH2(Throttle) Trim

Up
Down
CH2

Forward/Speed up Neutral Brake/Reverse Slow down
Throttle Trigger

If the wheels move forward without operation, adjust the CH2 downward.

If the wheels move backward without operation, adjust the CH2 upward .

CH1(Steering Reverse)

Reverse
CH1 CH2 CH3
CH2 EPA HI Lo
CH3

N
R

Use this adjustment for when the steering is reversed.

Left Steering Wheel

Left Steering Wheel

CH2(Throttle Reverse)

Reverse
CH1 CH2 CH3
CH2 EPA HI Lo
CH3

N
R

Use this adjustment for when the throttle is reversed.

Throttle Trigger

Throttle Trigger

CH2(Throttle end point)

Reverse
CH1 CH2 CH3
CH2 EPA HI Lo
CH3

CH2 EPA HI Lo

Use this adjustment for forward and brake side servo travel. Each direction can be adjusted independent of each other.

Throttle Trigger

Throttle Trigger

Receiver R-30I

Operating Instructions

System Specifications

Model: R-30I

Frequency: 2.4GHz FHSS

Operating Voltage: 6.0-8.4V (Alkaline/Ni-Cd/Ni-MH)
7.4-11.1V (Li-poly3S)

Mechanical Speed Control Setup

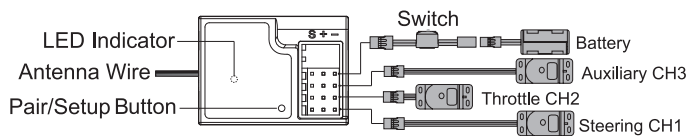

Electronic Speed Control Setup

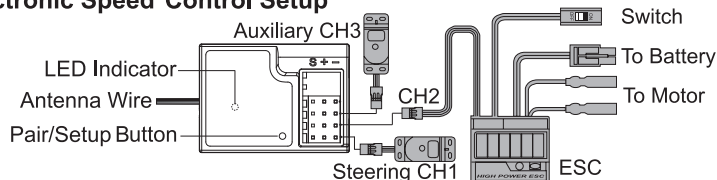

-30 & -30 Bind



R-30I



R-30I

Power off the transmitter. Press and hold the binding button on the receiver, in the meantime, turn the receiver on, the LED flashes quickly. Loosen the button.



T-30I



R-30I

Turn the transmitter on, it will bind with the receiver automatically. If the LED indicator on the receiver becomes and stays continuously lit, the binding is successfully setup.

! The receiver can only receive the signals transmitted by the transmitter once they are in successfully binding. Generally the two of them have been paired before leaving the factory, please check before use. If not, users can setup the binding according to the following steps.

! If the LED light is flashing or OFF, the setup failed. Please shorten the distance between the transmitter and the receiver, bind again. Long binding distance can cause setup failure, so please do not keep the receiver far away from the transmitter.

Fail-Safe setup procedure



T-30I



R-30I

Turn on the power switches of both the transmitter and receiver, the LED indicator lights should both be on.



R-30I



T-30I CH2

Press and hold the receiver setup button for 2 seconds, the LED rapid flash, in 5 seconds, put CH2 in the brake condition and hold it until the LED continuesly lit.

! Please note transmitter must be paired with receiver before setting up the S/F mode. The model car has been preset at a F/S mode to be automatically braked after running out of control. Check before use whether the the F/S mode still works. If not, follow these steps to reset.

! Any new binding of the transmitter and receiver should clear the preset fail-safe.

Receiver's Antenna Installation

The wave length of the 2.4GHz is much shorter than that of the conventional frequencies, it is very susceptible to loss of signal which results in a receiving error.

To obtain the best results, please refer to the following instructions;

1. The antenna must be kept as straight as possible. Otherwise it will reduce the effective range.
2. The antenna should be perpendicular to the model. Larger models can have large metal objects that can attenuate the RF signal. In this case the antennas should be placed at sides of the model. Then the best RF signal condition is obtained at any attitude.
3. The antennas must be kept away from conductive materials, such as metal and carbon by at least a half inch. The coaxial part of the antennas does not need to follow these guidelines, but do not bend it in a small radius.
4. Keep the antennas away from the motor, ESC, and other noise sources as much as possible

*The main purpose of the photo demonstrates how the antenna should be placed. For actual installation the receiver must be wrapped with a sponge or placed with floating material to protect it from vibration

The receiver contains precision electronic parts. It is the most delicate radio component on-board the model and should be protected from vibration, shock and temperature extremes. To protect the receiver, wrap it in R/C foam rubber or other vibration-absorbing material. If appropriate, waterproof the receiver by placing it in a plastic bag and closing the open end with a rubber band before wrapping it in foam. If moisture enters the receiver, intermittent operation or a failure may result. Wrapping the receiver in a plastic bag also protects it from fuel and exhaust residue which, in some models, can work its way into the model.

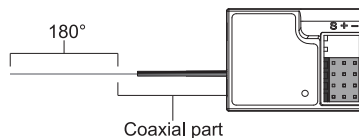

En **Manual Update**
De **Manuelles Update**
Fr **Mise à jour manuelle**
Es **Actualización manual**

**C-U01 USB
NiMH Charger**

500mA 2-6 cell NiMh (600-2500mAh) USB Charger
500mA 2-6S NiMh (600-2500mAh) USB Ladegerät
Chargeur 500mA 2-6S NiMh (600-2500mAh) USB
500mA 2-6S NiMh (600-2500mAh) Cargador USB

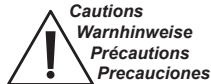

Cautions
Warnhinweise
Précautions
Precauciones

- The included charger is intended for use with the included NiMh battery pack only. **(Do not use with LiPo)**
- Use the charger with adult supervision. Do not use the charger near water or when wet.
- Do not use the charger if the wire is frayed or worn. If the wire is frayed or worn a short circuit can cause a fire or burns.
- Das mitgelieferte Ladegerät darf nur mit dem mitgelieferten NiMh-Akku verwendet werden. **(Nicht mit LiPo verwenden)**
- Verwenden Sie das Ladegerät unter Aufsicht von Erwachsenen. Verwenden Sie das Ladegerät nicht in der Nähe von Wasser oder bei Nässe.
- Verwenden Sie das Ladegerät nicht, wenn das Kabel ausgefranst oder abgenutzt ist. Wenn das Kabel ausgefranst oder abgenutzt ist, kann ein Kurzschluss einen Brand oder Verbrennungen verursachen.

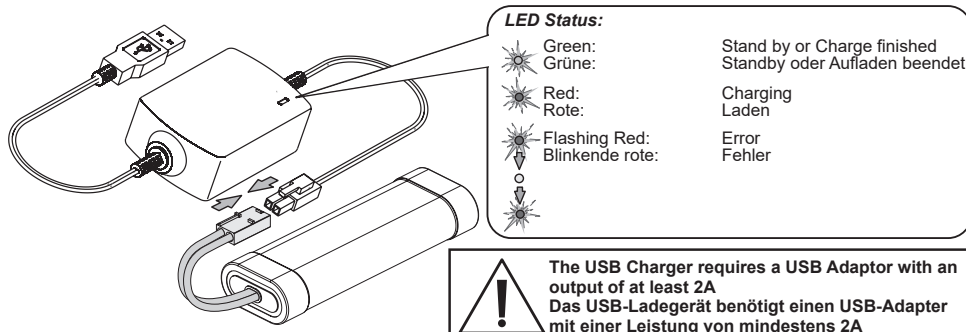

LED Status:

- Green: Stand by or Charge finished
Grüne: Standby oder Aufladen beendet
- Red: Charging
Rote: Laden
- Flashing Red: Error
Blinkende rote: Fehler



The USB Charger requires a USB Adaptor with an output of at least 2A
Das USB-Ladegerät benötigt einen USB-Adapter mit einer Leistung von mindestens 2A

1. Connect the charging socket to the supplied battery packs power plug. The connectors are sided and have a clip to secure it in place. Do not force together and always check you have the connection the right way round. You may need to use the included adaptor cable for your battery pack.
2. The charger will automatically start to charge your battery pack. The USB charger has Delta-Peak and will stop charging when it detects the battery pack is at full charge.
1. Schließen Sie die Ladebuchse an den mitgelieferten Stecker des Akkus an. Die Anschlüsse sind seitlich und haben einen Clip, um sie zu sichern. Nicht zusammenzwingen und immer prüfen, ob die Verbindung richtig herum ist. Möglicherweise müssen Sie das mitgelieferte Adapterkabel für Ihren Akku verwenden.
2. Das Ladegerät lädt Ihren Akku automatisch auf. Das USB-Ladegerät verfügt über Delta-Peak und stoppt den Ladevorgang, wenn festgestellt wird, dass der Akku voll aufgeladen ist.

Errors include:

- Voltage out of charging range - Your battery pack is outside the voltage range of the charger. If this is reoccurring your battery pack may be damaged and need replacing.
- Reverse Polarity Protection - Your battery pack has been plugged into the charger with the incorrect polarity.
- Processing Time Limit - Your battery has been on charge for longer than the allowed time limit (8h). If this is reoccurring your battery pack may be damaged and need replacing.

Zu den Fehlern gehören:

- Spannung außerhalb des Ladebereichs - Ihr Akku befindet sich außerhalb des Spannungsbereichs des Ladegeräts. Wenn dies erneut auftritt, ist Ihr Akku möglicherweise beschädigt und muss ersetzt werden.
- Verpolungsschutz - Ihr Akku wurde mit der falschen Polarität an das Ladegerät angeschlossen.
- Bearbeitungszeitlimit - Ihr Akku wurde länger als das zulässige Zeitlimit (8 Stunden) aufgeladen. Wenn dies erneut auftritt, ist Ihr Akku möglicherweise beschädigt und muss ersetzt werden.



Vestergaard A/S
Jegindoevej 21,
8800 Viborg,
Denmark
info@veste.dk

C-U01

En Manual Update
De Manuelles Update
Fr Mise à jour manuelle
Es Actualización manual

C-U01 USB
NiMh Charger

500mA 2-6 cell NiMh (600-2500mAh) USB Charger
500mA 2-6S NiMh (600-2500mAh) USB Ladegerät
Chargeur 500mA 2-6S NiMh (600-2500mAh) USB
500mA 2-6S NiMh (600-2500mAh) Cargador USB



Cautions
Warnhinweise
Précautions
Precauciones

- Le chargeur inclus est destiné à être utilisé uniquement avec la batterie NiMh incluse. **(Ne pas utiliser avec une batterie LiPo)**
- Utilisez le chargeur sous la surveillance d'un adulte. N'utilisez pas le chargeur près de l'eau ou lorsqu'il est mouillé. N'utilisez pas le chargeur si le fil est effiloché ou abimé, cela peut provoquer un incendie ou des brûlures.
- El cargador incluido está diseñado para usarse únicamente con la batería NiMh incluida. **(No usar con LiPo)**
- Use el cargador con supervisión de un adulto. No use el cargador cerca del agua o cuando esté mojado.
- No use el cargador si el cable está desgastado o desgastado. Si el cable está desgastado o desgastado, un cortocircuito puede provocar un incendio o quemaduras.

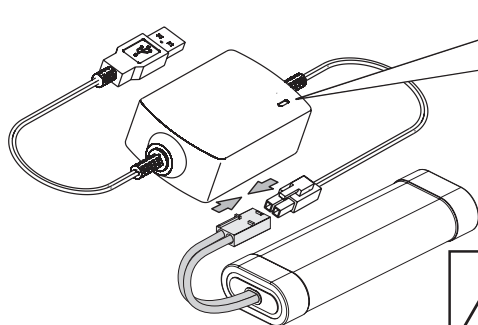

LED État, Estado:

	Verte:	Veille ou charge terminée
	Verde:	Espera o carga finalizada
	Rouge:	Charge
	Rojo:	Carga
	Rouge clignotante:	Erreur
	Rojo intermitente:	Error



Le chargeur USB nécessite un adaptateur USB avec une sortie d'au moins 2A
El cargador USB requiere un adaptador USB con una salida de al menos 2A

1. Branchez la prise de charge sur la fiche d'alimentation de la batterie. Les connecteurs ont un détrompeur et un clip pour le fixer en place. Ne forcez pas et vérifiez toujours que vous avez la connexion dans le bon sens. Vous devrez peut-être utiliser le câble adaptateur fourni pour votre batterie.
2. Le chargeur commencera automatiquement à charger votre batterie. Le chargeur USB Delta-Peak arrêtera de charger lorsqu'il détectera que la batterie est complètement chargée.
1. Conecte la toma de carga al enchufe de alimentación de los paquetes de baterías suministrados. Los conectores son laterales y tienen un clip para asegurarlo en su lugar. No fuerce juntos y siempre verifique que tenga la conexión de la manera correcta. Es posible que deba usar el cable adaptador incluido para su batería.
2. El cargador comenzará a cargar automáticamente su batería. El cargador USB tiene Delta-Peak y dejará de cargarse cuando detecte que la batería está completamente cargada.

Erreurs :

- Tension hors plage de charge - Votre batterie est en dehors de la plage de tension du chargeur. Si cela se reproduit, votre batterie peut être endommagée et doit être remplacée.
- Protection contre les inversions de polarité - Votre batterie a été branchée sur le chargeur avec une polarité incorrecte.
- Délai de traitement - Votre batterie est en charge depuis plus longtemps que le délai autorisé (8h). Si cela se reproduit, votre batterie peut être endommagée et devra être remplacée.

Los errores incluyen:

- Voltaje fuera del rango de carga: su batería está fuera del rango de voltaje del cargador. Si esto vuelve a ocurrir, su batería puede estar dañada y debe reemplazarse.
- Protección contra polaridad inversa: su batería fue conectada al cargador con la polaridad incorrecta.
- Límite de tiempo de procesamiento: su batería ha estado cargándose durante más tiempo que el límite de tiempo permitido (8h). Si esto vuelve a ocurrir, su batería puede estar dañada y debe reemplazarse.



Vestergaard A/S
Jegindoevej 21,
8800 Viborg,
Denmark,
info@veste.dk

C-U01

